

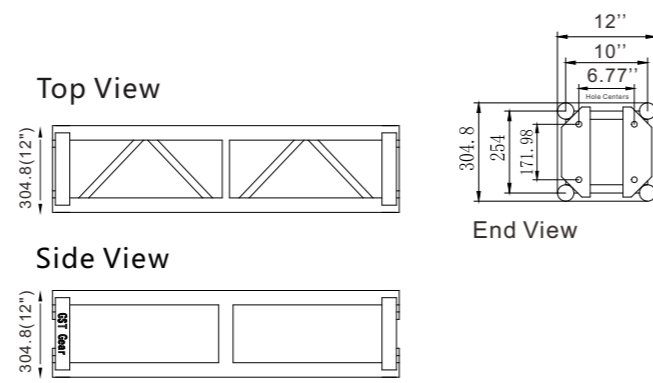

12" Compatible Box Bolt Truss: G34

12" Compatible Box Bolt Truss: G34

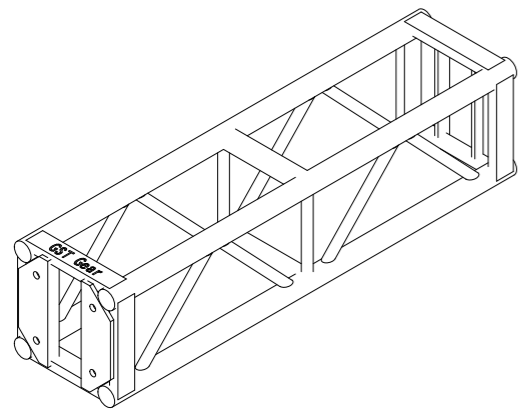

G34 aluminum plate bolt truss is suitable for all events and performances of all sizes, providing additional rigging capacities. Its durability and strength are specifically designed for high-frequency structural applications that require higher load-bearing. The truss can be customized to meet your requirements.



Compatible 36"x36" (914.4*914.4*15mm) Heavy Duty Base Plate for 12" & 20.5" Truss Compatible 12" 6 way Corner Block

* Truss is supplied in brushed aluminum finish with powder coated options upon request.

Facts		
• TÜV approved		
• Also available in any non-standard length and shape		
• Tolerance free conical connector system		
Specification		
Height	Metric: 304.8 mm	Imperial: 12 in
Width	Metric: 304.8 mm	Imperial: 12 in
Main Chords	Metric: 50.8 x 3.2 mm	Imperial: 2x0.13(1/8) in
Braces	Metric: 50.8 x 3.2 mm	Imperial: 2x0.13(1/8) in
Braces	Metric: 25.4 x 3.2 mm	Imperial: 1x0.13(1/8) in
Connection	Bolts and Nuts	
Material	EN AW-6061 T6	

Product Photos



Quality Inspection Checklist

- checked to drawing
- checked for twist
- all welds checked
- excessive weld residue removed
- sharp edges treated
- checked connection
- proper hardware included

Loading Recommendations

The truss incorporates diagonal bracing on two opposing faces. Its design load analysis assumed forces applied in one direction only, parallel to the braces on the opposite faces. Loading applied in multiple directions must be approved by a qualified person.

The structural analysis modeled the truss as a simple span, static beam. The span lengths listed in the table represent the distance between end supports. Use outside these parameters—including cantilevers, dynamic loads, or indeterminate structures—requires approval from a qualified person. The maximum span length indicated in the table must not be exceeded without such approval.

All applied loads and support points must be located at panel points within truss. The analysis assumed loads were applied at the truss centroid to prevent twisting; any unbalanced or off-center loading scenarios must be approved by a qualified person. The self-weight of the truss has already been deducted from the allowable load data.

The simple span lengths are based on configurations built from the minimum number of truss sections, each 10 feet long or less. For instance, a 26-foot span is assumed to consist of two 10-foot sections and one 6-foot section.

Please contact GST Gear with any questions.

Allowable Loading Table

SIMPLE SPAN (DISTANCE BETWEEN SUPPORTS)		UDL			MAXIMUM ALLOWABLE LOAD PER POINT							
		▼▼▼▼▼▼▼▼▼▼▼▼▼▼▼▼			CPL		THIRD POINT LOAD		QUARTER POINT LOAD		FIFTH POINT LOAD	
		LOAD	TOTAL LOAD	DEFLECTION	LOAD	DEFLECTION	LOAD	DEFLECTION	LOAD	DEFLECTION	LOAD	DEFLECTION
FEET	METERS	LBS/FT	LBS	INCHES	LBS	INCHES	LBS	INCHES	LBS	INCHES	LBS	INCHES
10	3	524	5236	0.43	2646	0.28	1962	0.31	1312	0.35	1091	0.39
15	4.6	231	3472	0.59	1764	0.47	1323	0.59	882	0.59	716	0.59
20	6.1	127	2535	0.86	1268	0.71	937	0.83	661	0.86	551	0.90
25	7.6	79	1984	1.14	992	0.90	772	1.18	496	1.02	441	1.26
30	9.1	53	1598	1.41	827	1.22	606	1.38	386	1.30	331	1.38
35	10.7	38	1323	1.81	661	1.38	496	1.85	331	1.39	276	1.81
40	12.2	28	1102	2.16	551	1.73	441	2.67	276	2.16	220	2.12
45	13.7	21	937	2.71	496	2.40	386	3.30	220	2.59	220	3.30
50	15.2	15	772	2.79	386	2.44	276	3.03	220	3.38	165	3.18